

Microwave



A microwave that grills

With features such as integrated turntable design, quartz grill and diamond deflector, the Kleenmaid microwave ensures even heat distribution and cooking temperature for excellent cooking results. The separate grill function means you can use your microwave for more than just reheating food. Additionally you can enter your food type and the auto program function will calculate the most appropriate cooking time for you.

Features:

Capacity:	30 litres
Operation:	manual & semi automatic programs
Grill:	Closed door grilling
Power:	15 amp required
Timer:	Fully programmable electronic timer
Accessories:	Grill rack Round glass tray Duplex double tray Recipe book

10

10 Year Warranty*

For your nearest store call 13 13 08
www.kleenmaid.com.au

Kleenmaid
 The best you can own.

Microwave

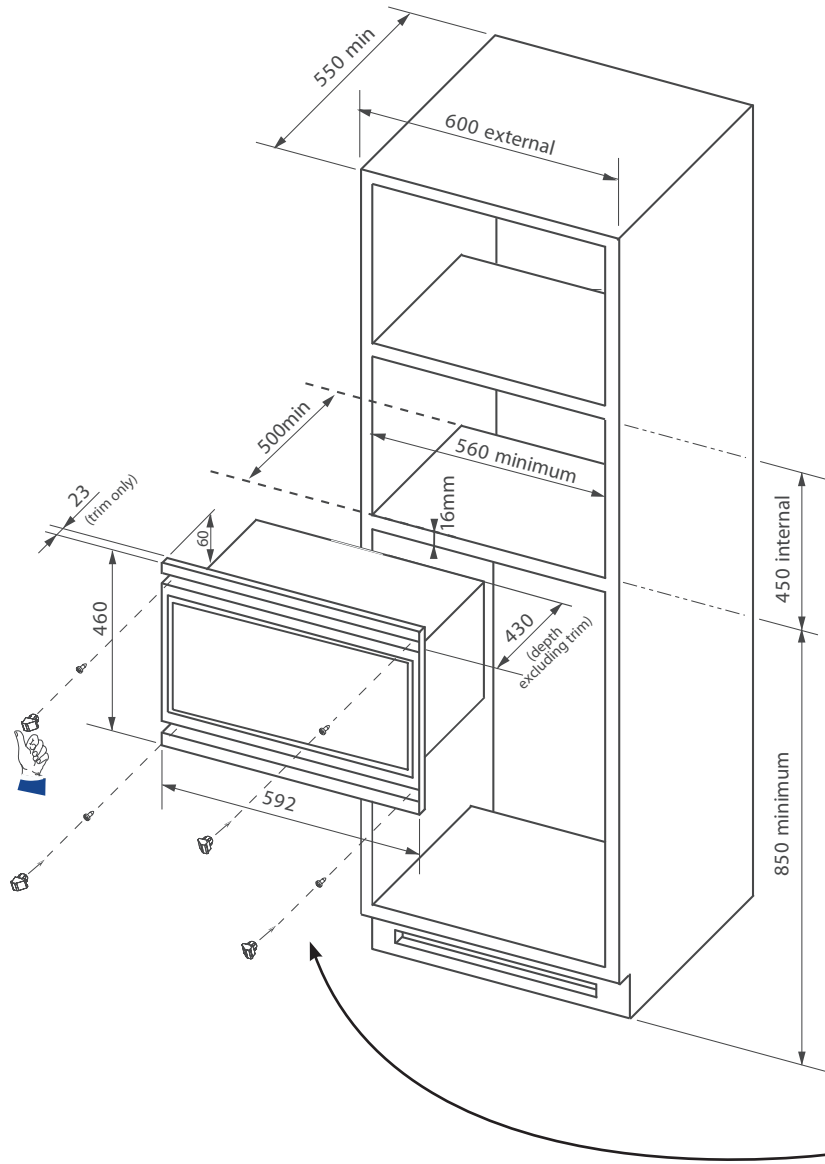

BUILDING-IN

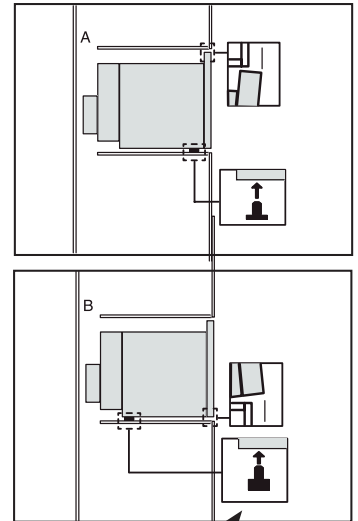

INCLUSIONS

	X 1
	X 4
	X 4

NOTES:

- MWK101X comes with trim attached and must be built-in.
- Trim will extend 5mm at top and bottom over cavity (450mm)
- Unit cannot be freestanding or installed under-bench due to venting and height requirement
- Minimum height above floor is 850mm due to front door temperatures
- Building-in diagrams shown from Use & Care Manual refers to spacers provided for minor height adjustment
- Trim Kit MWT901X also available to integrate with a TO901X oven

Model	Approval No.	Electrical Ratings	Comments
MWK101X	Q03502	240V 50Hz 2750W	Comes with a 15AMP plug

*Technical Specifications and product sizes can be varied by Manufacturer without notice. Any cut-outs for appliances should only be by physical measurements. Drawings are not to scale. All information supplied is for general reference purposes only and is on the understanding that Kleenmaid Pty Ltd will not be liable for any loss, liability or damage whatsoever arising as a result of reliance of such information.